

A1C Double Flex Aluminum

Performance Information

Model	Continuous Rated Torque	Peak Rated Torque	Torsional Stiffness	Maximum Speed	Misalignments			Unit Weight at		Inertia at	
					Angular	Parallel	Axial	Max. Bore	Min. Bore	Max. Bore	Min. Bore
					Degrees °	mm	mm	kg	kg	kg-cm ²	kg-cm ²
6P18-A1C	20	40	5500	15000	2	0.44	1.6	0.25	0.3	3	1.1
6P22-A1C	30	60	8482	13500	2	0.58	1.8	0.39	0.47	2.2	2.4
6P26-A1C	53	106	9712	11500	2	0.55	2.2	0.54	0.65	4.1	4.3
6P30-A1C	90	180	20923	9500	2	0.85	2.6	0.97	1.14	10	11
6P37-A1C	181	362	32700	7900	2	1	3.6	2.03	2.43	31.7	33.1
6P45-A1C	282	564	60324	6700	2	1.24	4.6	3.7	4.6	85	90

- Consult Zero-Max for speeds higher than those listed and balancing requirements, if necessary.
- Consult Zero-Max for higher torque and higher torsional stiffness couplings.

Dimensional Information

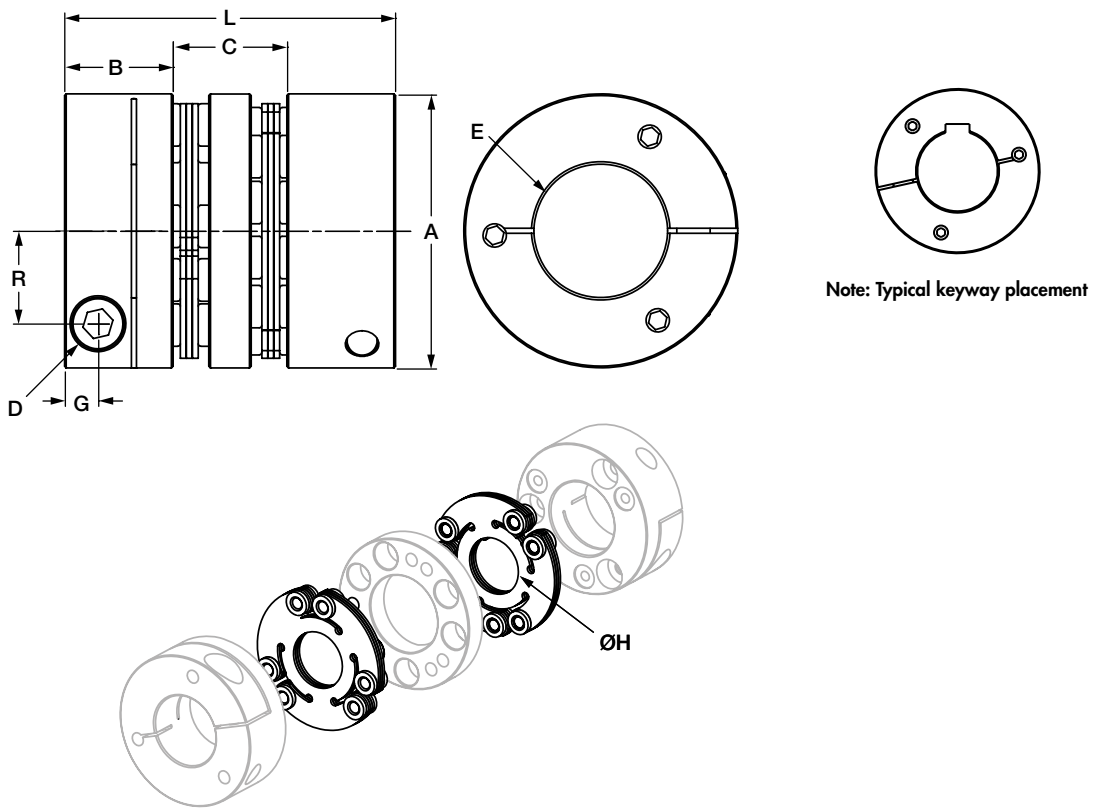

Model	A	B	C	E Bore		G	H	L	R	D
				Min.	Max.					
				mm	mm					
6P18-A1C	53	22.5	18	8	26	7.2	20.1	63	18	M6
6P22-A1C	62	26	23	12	31	7.2	24.9	75	22	M6
6P26-A1C	69.5	29.5	22	14	35	9.1	25.4	81	24	M8
6P30-A1C	82	32.5	34	16	40	10	31	99	27.8	M10
6P37-A1C	101	46	42	18	51	12.7	38	134	36	M12
6P45-A1C	123	60	48	24	65	16.9	46	168	43.5	M16

Bore size (metric)

Model	8	9	10	11	12	13	14	15	16	17	18	19	20	22	24	25	26	28	30	32	35	38	40	42	45	48	50	52	55	58	60	62	65		
6P18-A1C	●	●	●	●	●	●	●	●	●	●	●	●	●	●	●	●	●																		
6P22-A1C					●	●	●	●	●	●	●	●	●	●	●	●	●	●	●	●															
6P26-A1C							●	●	●	●	●	●	●	●	●	●	●	●	●	●	●	●													
6P30-A1C									●	●	●	●	●	●	●	●	●	●	●	●	●	●	●	●											
6P37-A1C											●	●	●	●	●	●	●	●	●	●	●	●	●	●	●	●	●	●							
6P45-A1C																●	●	●	●	●	●	●	●	●	●	●	●	●	●	●	●	●	●	●	●

• The coupling will transmit full peak torque on a shaft without a keyway. Please contact Zero-Max for additional bores.

How to Order

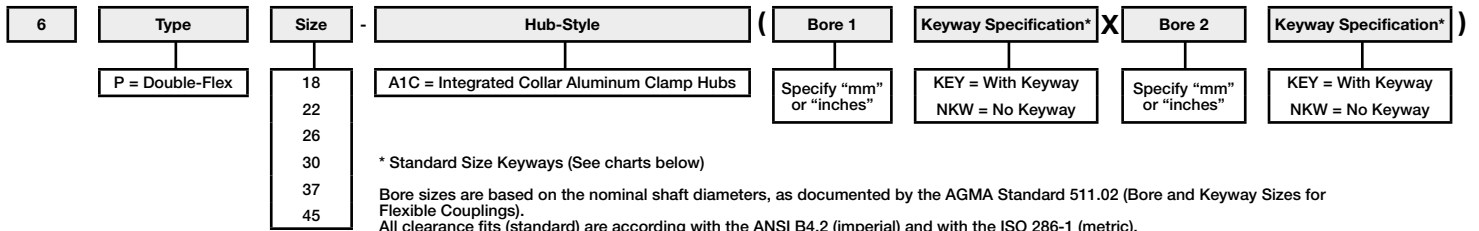

Note: The hub design of Series A1C CD Couplings will provide the necessary clamping force to hold the shaft in a dynamic application without the use of keyways for all bore sizes listed in catalog. Other hub designs on request.

Bore Size (mm)		Keyway	Bore Size (mm)		Keyway
Over	To		Over	To	
10	12	4 x 1.8	58	65	18 x 4.4
12	17	5 x 2.3	65	75	20 x 4.9
17	22	6 x 2.8	75	85	22 x 5.4
22	30	8 x 3.3	85	95	25 x 5.4
30	38	10 x 3.3	95	110	28 x 6.4
38	44	12 x 3.3	110	130	32 x 7.4
44	50	14 x 3.8	130	150	36 x 8.4
50	58	16 x 4.3	150	170	40 x 9.4

Bore Size (mm)		Keyway	Bore Size (mm)		Keyway
Over	To		Over	To	
0.437	0.562	0.125 x 0.062	2.250	2.750	0.625 x 0.312
0.562	0.875	0.187 x 0.094	2.750	3.250	0.750 x 0.375
0.875	1.250	0.250 x 0.125	3.250	3.750	0.875 x 0.437
1.250	1.375	0.312 x 0.156	3.750	4.500	1.000 x 0.500
1.375	1.750	0.375 x 0.187	4.500	5.500	1.250 x 0.625
1.750	2.250	0.500 x 0.250	5.500	6.500	1.500 x 0.750

Example: 6P30-A1C (20mm NKW x 30mm KEY)