

Series 300F

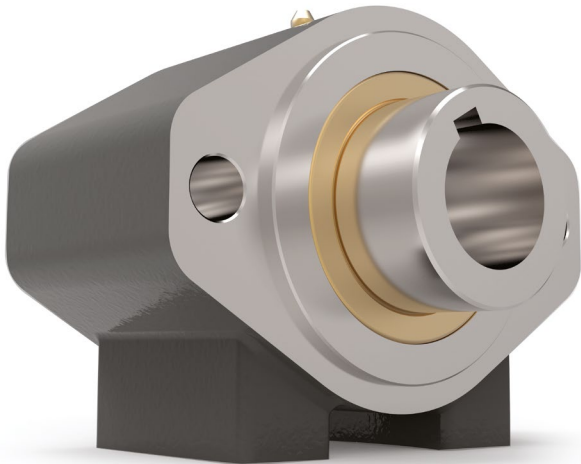

Features

- SAE A 2-bolt mounting
- Heavy Duty Deep Groove Ball Bearings
- May be either Face-mounted or Foot-mounted
- Provides a sturdy mounting base for the motor or pump
- Supports heavy radial and axial loads – protecting the hydraulic motor or pump
- Reduces downtime and maintenance costs
- Protects pump or motor shaft seal from harmful contaminants
- Other versions with adaptor mounting for DIN, ISO, IEC or NEMA motors

300F Series Data

Input Standard	SAE A 2-bolt
Input Pilot Diameter	82.55 mm
Input Pilot Depth	Standard Housing 3.18 mm Deep Pilot (optional) 6.35 mm
Input Pilot Sealing Method	Buna-N Gasket
Input Bore Diameter and Depth	31.75 mm through-bore
Output Shaft Diameter	31.75 mm through-bore
Output Shaft Keyway	7.94 mm x 3.97 mm Keyway (the entire length of the bore)
Output Shaft Length	25.4 mm extension
Output Shaft Seal Type	Double-lip with Garter Spring
Output Pilot Diameter	82.55 mm
Output Pilot Height	3.18 mm
Shaft Material	Stressproof Steel (1.0762) or an equivalent
Bearing Type	Deep Groove Ball Bearings
Standard Lubrication Method	Grease
Optional Lubrication Methods	Please consult Zero-Max.
Grease Fitting	(1) Standard Zerk Fitting
Grease Capacity	Minimum ca. 20 ml Maximum ca. 40 ml
Grease Type (recommended for typical applications)	NLGI #2
Recommended Grease Base	Lithium
Standard Mounting Orientation	Shaft Horizontal – Consult Zero-Max for other Mounting Orientations.
Maximum Speed Without Modification	3100 RPM
Housing Material	Cast Iron
Housing Feet - Threaded Holes	(4) 3/8"-16 UNC x 17.25 mm
Housing Grease Ports	Press-fit Zerk Fitting
Unit Weight	4.54 kg

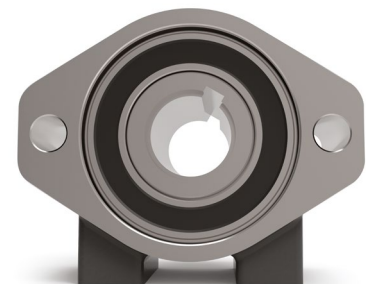
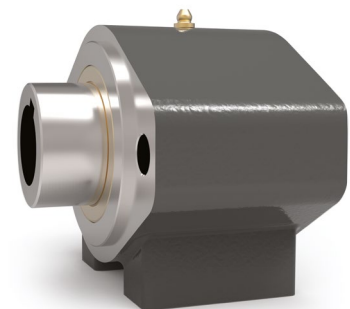

Technical Information (all dimensions in mm)

Input End View

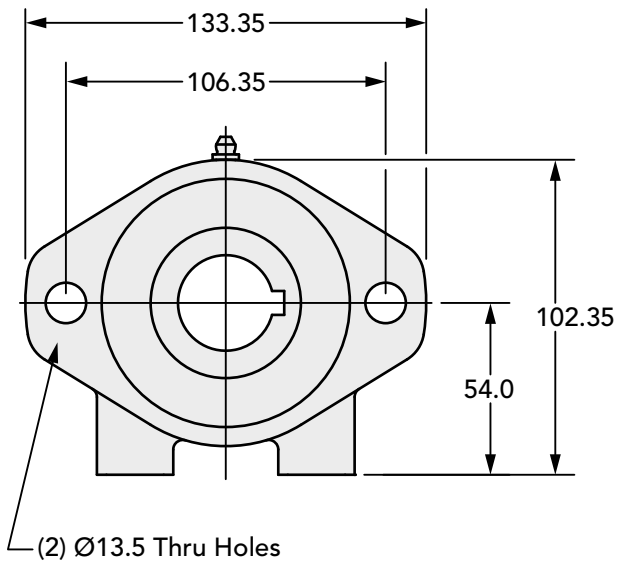

Side View

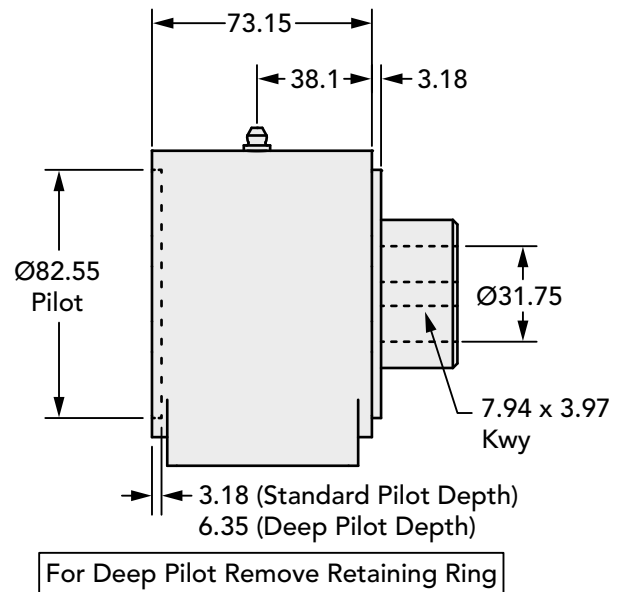

Bottom View

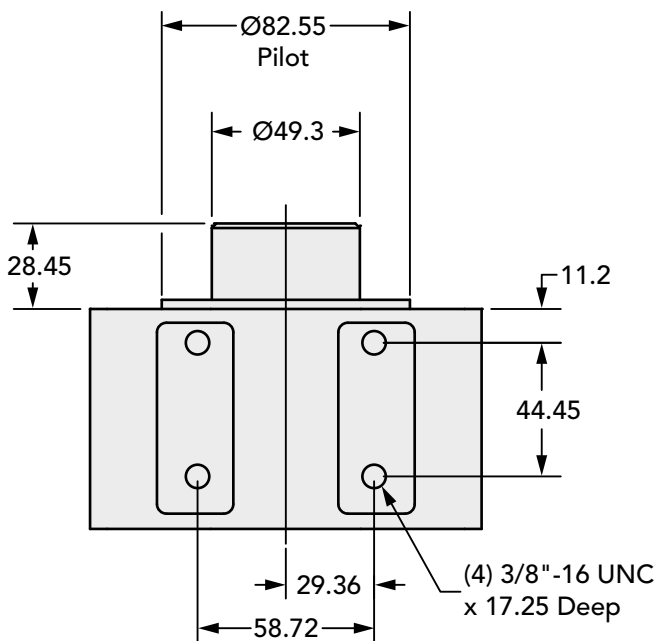

How to Order

Standard 300F Series Data

Model	Output Shaft - Keyway	Input Bore - Keyway
300F	31.75 mm - 7.94 mm x 3.97 mm	31.75 mm - 7.94 mm x 3.97 mm
300F-DP	31.75 mm - 7.94 mm x 3.97 mm	31.75 mm - 7.94 mm x 3.97 mm

Note: Models with -DP on the end call out a Deep pilot option.
Standard pilot depth is 3.18 mm and the Deep pilot depth is 6.35 mm.