

Series 415

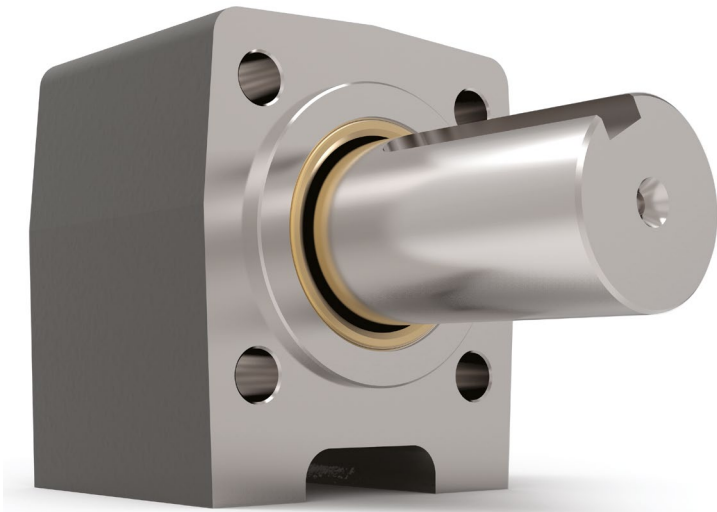

Features

- Non-SAE 4-bolt mounting
- Deep Groove Ball Bearings
- May be either Face-mounted or Foot-mounted
- Provides a sturdy mounting base for the motor or pump
- Supports heavy radial and axial loads – protecting the hydraulic motor or pump
- Reduces downtime and maintenance costs
- Protects pump or motor shaft seal from harmful contaminants
- Other versions with adaptor mounting for DIN, ISO, IEC or NEMA motors

415 Series Data

Input Standard	Non-SAE 4-bolt mount (designed to fit a popular LSHT Geroler motor)
Input Pilot Diameter	44.45 mm
Input Pilot Depth	3.18 mm
Input Pilot Sealing Method	Fiber Gasket
Input Bore Diameter and Depth	25.4 mm keyed (bore depth 55 mm)
Output Shaft Diameter	38.1 mm
Output Shaft Keyway	9.53 mm x 4.76 mm keyway
Output Shaft Keyway Length	52.3 mm
Output Shaft Length	72.9 mm
Output Pilot Diameter	63.5 mm
Output Pilot Height	3.18 mm
Shaft Material	Stressproof Steel (1.0762) or an equivalent
Bearing Type	Deep Groove Ball Bearings
Standard Lubrication Method	Grease
Optional Lubrication Methods	Please consult Zero-Max.
Grease Fitting	(1) Standard Zerk Fitting
Grease Capacity	Minimum ca. 12 ml Maximum ca. 30 ml
Grease Type (recommended for typical applications)	NLGI #2
Recommended Grease Base	Lithium
Standard Mounting Orientation	Shaft Horizontal – Consult Zero-Max for other Mounting Orientations.
Maximum Speed Without Modification	3800 RPM
Housing Material	Cast Iron
Housing Feet - Threaded Holes	(4) 3/8"-16 UNC x 17.25 mm
Housing Grease Ports	Press-fit Zerk Fitting
Unit Weight	4.54 kg

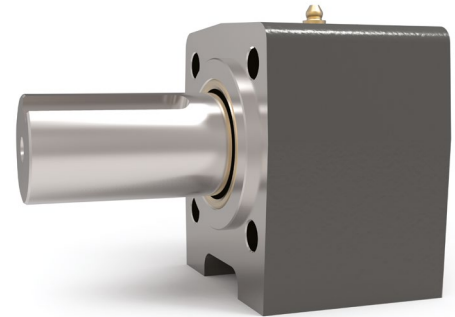

Technical Information (all dimensions in mm)

Input End View

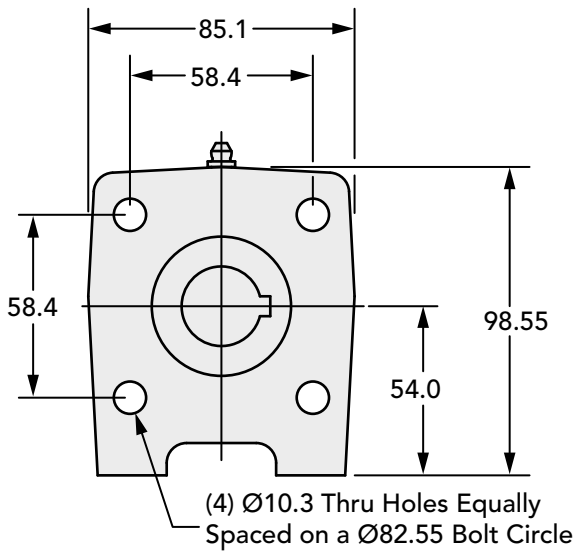

Side View

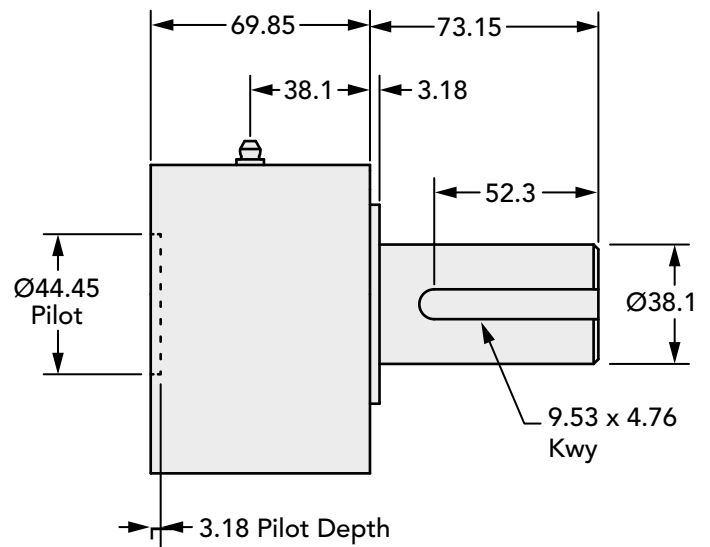

Bottom View

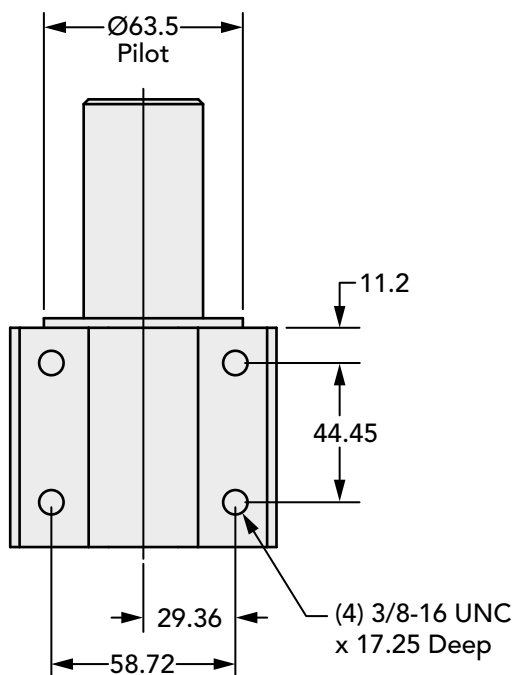

How to Order

415 Series Data

Model	Output Shaft – Keyway	Input Bore – Keyway
415	38.1 mm – 9.53 mm x 4.76 mm	25.4 mm – 6.35 mm x 3.18 mm