

# SERVOFLEX SFH G - Datasheet

## DOUBLE ELEMENT / Key/Set Screw Type

### Specifications

Model	Rated torque [N-m]	Misalignment			Max. rotation speed [min <sup>-1</sup> ]	Torsional stiffness [N-m/rad]	Axial stiffness [N/mm]	Moment of inertia [kg-m <sup>2</sup> ]	Mass [kg]
		Parallel [mm]	Angular [°]	Axial [mm]					
SFH-150G	1000	1.4	2	± 0.8	5900	750000	122	21.87 × 10 <sup>-3</sup>	8.72
SFH-170G	1300	1.6	2	± 1.0	5100	1420000	112	51.07 × 10 <sup>-3</sup>	13.94
SFH-190G	2000	2	2	± 1.0	4700	1700000	122	81.58 × 10 <sup>-3</sup>	19.51
SFH-210G	4000	2.1	2	± 1.1	4300	2340000	254	125.50 × 10 <sup>-3</sup>	24.26
SFH-220G	5000	2.3	2	± 1.2	4000	2970000	224	176.91 × 10 <sup>-3</sup>	30.27
SFH-260G	8000	2.9	2	± 1.4	3400	5390000	306	433.47 × 10 <sup>-3</sup>	53.11

• Higher rpm possible with balancing.  
 • The moment of inertia and mass are specified for the maximum bore diameter.

### Dimensions

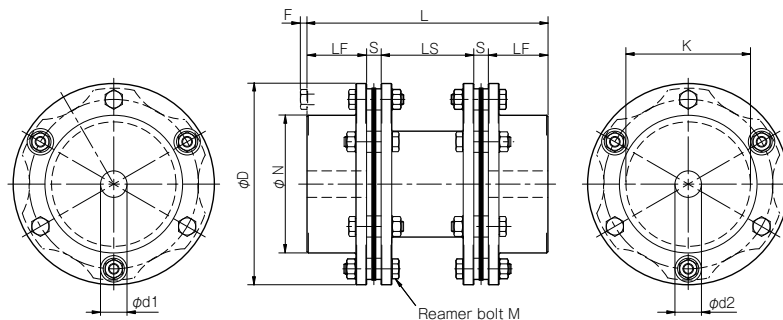

Unit [mm]

Model	d1 • d2			D	N	L	LF	LS	S	F	K	M
	Pilot bore	Min.	Max.									
SFH-150G	20	22	70	152	104	182	45	70	11	5	94	12-M8 × 36
SFH-170G	25	28	80	178	118	218	55	80	14	6	108	12-M10 × 45
SFH-190G	30	32	85	190	126	260	65	100	15	10	116	12-M12 × 54
SFH-210G	35	38	90	210	130	290	75	110	15	8	124	12-M16 × 60
SFH-220G	45	48	100	225	144	335	90	115	20	-2	132	12-M16 × 60
SFH-260G	50	55	115	262	166	391	100	145	23	11	150	12-M20 × 80

• Further dimensions for LS possible on request.

### How to Place an Order

**SFH-150G-38H-38H LS=500**

Size: SFH-150G, Type: G, Double element, Bore diameter: d1 (Small diameter) - d2 (Large diameter), Blank: Pilot bore, Spacer length: LS=500

Bore specifications:  
 Blank: Compliant with the old JIS standards (class 2) E9  
 H: Compliant with JIS standards H9  
 N: Compliant with motor standards

Material: S45C steel or an equivalent

### Maximum LS Dimension When Used Vertically

Model	LS [mm]
SFH-150G	1100
SFH-170G	800
SFH-190G	900
SFH-210G	2000
SFH-220G	1900
SFH-260G	2500

• When considering vertical use and the LS dimension is greater than that in the above table, contact Miki Pulley.

## Standard Hole-Drillings

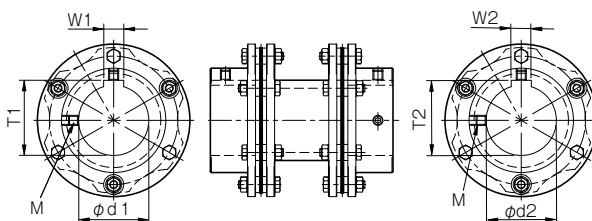

Unit [mm]

Models compliant with the old JIS standard (class 2) JIS B 1301 1959					Models compliant with the new JIS standard (H9) JIS B 1301 1996					Models compliant with the motor standard JIS C 4210 2001				
Nominal bore diameter	Bore diameter [d1 · d2]	Keyway width [W1 · W2]	Keyway height [T1 · T2]	Set screw hole [M]	Nominal bore diameter	Bore diameter [d1 · d2]	Keyway width [W1 · W2]	Keyway height [T1 · T2]	Set screw hole [M]	Nominal bore diameter	Bore diameter [d1 · d2]	Keyway width [W1 · W2]	Keyway height [T1 · T2]	Set screw hole [M]
	Tolerance H7	Tolerance E9	—	—		Tolerance H7	Tolerance H9	—	—		Tolerance G7, F7	Tolerance H9	—	—
22	22 <sup>+0.021</sup> <sub>0</sub>	7 <sup>+0.061</sup> <sub>+0.025</sub>	25.0 <sup>+0.3</sup> <sub>0</sub>	2-M6	22H	22 <sup>+0.021</sup> <sub>0</sub>	6 <sup>+0.030</sup> <sub>0</sub>	24.8 <sup>+0.3</sup> <sub>0</sub>	2-M5	—	—	—	—	—
24	24 <sup>+0.021</sup> <sub>0</sub>	7 <sup>+0.061</sup> <sub>+0.025</sub>	27.0 <sup>+0.3</sup> <sub>0</sub>	2-M6	24H	24 <sup>+0.021</sup> <sub>0</sub>	8 <sup>+0.036</sup> <sub>0</sub>	27.3 <sup>+0.3</sup> <sub>0</sub>	2-M6	24N	24 <sup>+0.028</sup> <sub>+0.007</sub>	8 <sup>+0.036</sup> <sub>0</sub>	27.3 <sup>+0.3</sup> <sub>0</sub>	2-M6
25	25 <sup>+0.021</sup> <sub>0</sub>	7 <sup>+0.061</sup> <sub>+0.025</sub>	28.0 <sup>+0.3</sup> <sub>0</sub>	2-M6	25H	25 <sup>+0.021</sup> <sub>0</sub>	8 <sup>+0.036</sup> <sub>0</sub>	28.3 <sup>+0.3</sup> <sub>0</sub>	2-M6	—	—	—	—	—
28	28 <sup>+0.021</sup> <sub>0</sub>	7 <sup>+0.061</sup> <sub>+0.025</sub>	31.0 <sup>+0.3</sup> <sub>0</sub>	2-M6	28H	28 <sup>+0.021</sup> <sub>0</sub>	8 <sup>+0.036</sup> <sub>0</sub>	31.3 <sup>+0.3</sup> <sub>0</sub>	2-M6	28N	28 <sup>+0.028</sup> <sub>+0.007</sub>	8 <sup>+0.036</sup> <sub>0</sub>	31.3 <sup>+0.3</sup> <sub>0</sub>	2-M6
30	30 <sup>+0.021</sup> <sub>0</sub>	7 <sup>+0.061</sup> <sub>+0.025</sub>	33.0 <sup>+0.3</sup> <sub>0</sub>	2-M6	30H	30 <sup>+0.021</sup> <sub>0</sub>	8 <sup>+0.036</sup> <sub>0</sub>	33.3 <sup>+0.3</sup> <sub>0</sub>	2-M6	—	—	—	—	—
32	32 <sup>+0.025</sup> <sub>0</sub>	10 <sup>+0.061</sup> <sub>+0.025</sub>	35.5 <sup>+0.3</sup> <sub>0</sub>	2-M8	32H	32 <sup>+0.025</sup> <sub>0</sub>	10 <sup>+0.036</sup> <sub>0</sub>	35.3 <sup>+0.3</sup> <sub>0</sub>	2-M8	—	—	—	—	—
35	35 <sup>+0.025</sup> <sub>0</sub>	10 <sup>+0.061</sup> <sub>+0.025</sub>	38.5 <sup>+0.3</sup> <sub>0</sub>	2-M8	35H	35 <sup>+0.025</sup> <sub>0</sub>	10 <sup>+0.036</sup> <sub>0</sub>	38.3 <sup>+0.3</sup> <sub>0</sub>	2-M8	—	—	—	—	—
38	38 <sup>+0.025</sup> <sub>0</sub>	10 <sup>+0.061</sup> <sub>+0.025</sub>	41.5 <sup>+0.3</sup> <sub>0</sub>	2-M8	38H	38 <sup>+0.025</sup> <sub>0</sub>	10 <sup>+0.036</sup> <sub>0</sub>	41.3 <sup>+0.3</sup> <sub>0</sub>	2-M8	38N	38 <sup>+0.050</sup> <sub>+0.025</sub>	10 <sup>+0.036</sup> <sub>0</sub>	41.3 <sup>+0.3</sup> <sub>0</sub>	2-M8
40	40 <sup>+0.025</sup> <sub>0</sub>	10 <sup>+0.061</sup> <sub>+0.025</sub>	43.5 <sup>+0.3</sup> <sub>0</sub>	2-M8	40H	40 <sup>+0.025</sup> <sub>0</sub>	12 <sup>+0.043</sup> <sub>0</sub>	43.3 <sup>+0.3</sup> <sub>0</sub>	2-M8	—	—	—	—	—
42	42 <sup>+0.025</sup> <sub>0</sub>	12 <sup>+0.075</sup> <sub>+0.032</sub>	45.5 <sup>+0.3</sup> <sub>0</sub>	2-M8	42H	42 <sup>+0.025</sup> <sub>0</sub>	12 <sup>+0.043</sup> <sub>0</sub>	45.3 <sup>+0.3</sup> <sub>0</sub>	2-M8	42N	42 <sup>+0.050</sup> <sub>+0.025</sub>	12 <sup>+0.043</sup> <sub>0</sub>	45.3 <sup>+0.3</sup> <sub>0</sub>	2-M8
45	45 <sup>+0.025</sup> <sub>0</sub>	12 <sup>+0.075</sup> <sub>+0.032</sub>	48.5 <sup>+0.3</sup> <sub>0</sub>	2-M8	45H	45 <sup>+0.025</sup> <sub>0</sub>	14 <sup>+0.043</sup> <sub>0</sub>	48.8 <sup>+0.3</sup> <sub>0</sub>	2-M10	—	—	—	—	—
48	48 <sup>+0.025</sup> <sub>0</sub>	12 <sup>+0.075</sup> <sub>+0.032</sub>	51.5 <sup>+0.3</sup> <sub>0</sub>	2-M8	48H	48 <sup>+0.025</sup> <sub>0</sub>	14 <sup>+0.043</sup> <sub>0</sub>	51.8 <sup>+0.3</sup> <sub>0</sub>	2-M10	48N	48 <sup>+0.050</sup> <sub>+0.025</sub>	14 <sup>+0.043</sup> <sub>0</sub>	51.8 <sup>+0.3</sup> <sub>0</sub>	2-M10
50	50 <sup>+0.025</sup> <sub>0</sub>	12 <sup>+0.075</sup> <sub>+0.032</sub>	53.5 <sup>+0.3</sup> <sub>0</sub>	2-M8	50H	50 <sup>+0.025</sup> <sub>0</sub>	14 <sup>+0.043</sup> <sub>0</sub>	53.8 <sup>+0.3</sup> <sub>0</sub>	2-M10	—	—	—	—	—
55	55 <sup>+0.030</sup> <sub>0</sub>	15 <sup>+0.075</sup> <sub>+0.032</sub>	60.0 <sup>+0.3</sup> <sub>0</sub>	2-M10	55H	55 <sup>+0.030</sup> <sub>0</sub>	16 <sup>+0.043</sup> <sub>0</sub>	59.3 <sup>+0.3</sup> <sub>0</sub>	2-M10	55N	55 <sup>+0.060</sup> <sub>+0.030</sub>	16 <sup>+0.043</sup> <sub>0</sub>	59.3 <sup>+0.3</sup> <sub>0</sub>	2-M10
56	56 <sup>+0.030</sup> <sub>0</sub>	15 <sup>+0.075</sup> <sub>+0.032</sub>	61.0 <sup>+0.3</sup> <sub>0</sub>	2-M10	56H	56 <sup>+0.030</sup> <sub>0</sub>	16 <sup>+0.043</sup> <sub>0</sub>	60.3 <sup>+0.3</sup> <sub>0</sub>	2-M10	—	—	—	—	—
60	60 <sup>+0.030</sup> <sub>0</sub>	15 <sup>+0.075</sup> <sub>+0.032</sub>	65.0 <sup>+0.3</sup> <sub>0</sub>	2-M10	60H	60 <sup>+0.030</sup> <sub>0</sub>	18 <sup>+0.043</sup> <sub>0</sub>	64.4 <sup>+0.3</sup> <sub>0</sub>	2-M10	60N	60 <sup>+0.060</sup> <sub>+0.030</sub>	18 <sup>+0.043</sup> <sub>0</sub>	64.4 <sup>+0.3</sup> <sub>0</sub>	2-M10
65	65 <sup>+0.030</sup> <sub>0</sub>	18 <sup>+0.075</sup> <sub>+0.032</sub>	71.0 <sup>+0.3</sup> <sub>0</sub>	2-M10	65H	65 <sup>+0.030</sup> <sub>0</sub>	18 <sup>+0.043</sup> <sub>0</sub>	69.4 <sup>+0.3</sup> <sub>0</sub>	2-M10	65N	65 <sup>+0.060</sup> <sub>+0.030</sub>	18 <sup>+0.043</sup> <sub>0</sub>	69.4 <sup>+0.3</sup> <sub>0</sub>	2-M10
70	70 <sup>+0.030</sup> <sub>0</sub>	18 <sup>+0.075</sup> <sub>+0.032</sub>	76.0 <sup>+0.3</sup> <sub>0</sub>	2-M10	70H	70 <sup>+0.030</sup> <sub>0</sub>	20 <sup>+0.052</sup> <sub>0</sub>	74.9 <sup>+0.5</sup> <sub>0</sub>	2-M10	—	—	—	—	—
75	75 <sup>+0.030</sup> <sub>0</sub>	20 <sup>+0.095</sup> <sub>+0.040</sub>	81.0 <sup>+0.5</sup> <sub>0</sub>	2-M10	75H	75 <sup>+0.030</sup> <sub>0</sub>	20 <sup>+0.052</sup> <sub>0</sub>	79.9 <sup>+0.5</sup> <sub>0</sub>	2-M10	75N	75 <sup>+0.060</sup> <sub>+0.030</sub>	20 <sup>+0.052</sup> <sub>0</sub>	79.9 <sup>+0.5</sup> <sub>0</sub>	2-M10
80	80 <sup>+0.030</sup> <sub>0</sub>	20 <sup>+0.095</sup> <sub>+0.040</sub>	86.0 <sup>+0.5</sup> <sub>0</sub>	2-M10	80H	80 <sup>+0.030</sup> <sub>0</sub>	22 <sup>+0.052</sup> <sub>0</sub>	85.4 <sup>+0.5</sup> <sub>0</sub>	2-M12	—	—	—	—	—
85	85 <sup>+0.035</sup> <sub>0</sub>	24 <sup>+0.095</sup> <sub>+0.040</sub>	93.0 <sup>+0.5</sup> <sub>0</sub>	2-M12	85H	85 <sup>+0.035</sup> <sub>0</sub>	22 <sup>+0.052</sup> <sub>0</sub>	90.4 <sup>+0.5</sup> <sub>0</sub>	2-M12	85N	85 <sup>+0.071</sup> <sub>+0.036</sub>	22 <sup>+0.052</sup> <sub>0</sub>	90.4 <sup>+0.5</sup> <sub>0</sub>	2-M12
90	90 <sup>+0.035</sup> <sub>0</sub>	24 <sup>+0.095</sup> <sub>+0.040</sub>	98.0 <sup>+0.5</sup> <sub>0</sub>	2-M12	90H	90 <sup>+0.035</sup> <sub>0</sub>	25 <sup>+0.052</sup> <sub>0</sub>	95.4 <sup>+0.5</sup> <sub>0</sub>	2-M12	—	—	—	—	—
95	95 <sup>+0.035</sup> <sub>0</sub>	24 <sup>+0.095</sup> <sub>+0.040</sub>	103.0 <sup>+0.5</sup> <sub>0</sub>	2-M12	95H	95 <sup>+0.035</sup> <sub>0</sub>	25 <sup>+0.052</sup> <sub>0</sub>	100.4 <sup>+0.5</sup> <sub>0</sub>	2-M12	95N	95 <sup>+0.071</sup> <sub>+0.036</sub>	25 <sup>+0.052</sup> <sub>0</sub>	100.4 <sup>+0.5</sup> <sub>0</sub>	2-M12
100	100 <sup>+0.035</sup> <sub>0</sub>	28 <sup>+0.095</sup> <sub>+0.040</sub>	109.0 <sup>+0.5</sup> <sub>0</sub>	2-M12	100H	100 <sup>+0.035</sup> <sub>0</sub>	28 <sup>+0.052</sup> <sub>0</sub>	106.4 <sup>+0.5</sup> <sub>0</sub>	2-M12	—	—	—	—	—
115	115 <sup>+0.035</sup> <sub>0</sub>	32 <sup>+0.112</sup> <sub>+0.050</sub>	125.0 <sup>+0.5</sup> <sub>0</sub>	2-M12	115H	115 <sup>+0.035</sup> <sub>0</sub>	32 <sup>+0.062</sup> <sub>0</sub>	122.4 <sup>+0.5</sup> <sub>0</sub>	2-M12	—	—	—	—	—

## Set Screw Position

## NOTE

Model	Position of set screw [mm]
SFH-150	15
SFH-170	20
SFH-190	25
SFH-210	30
SFH-220	35
SFH-260	40

- Positioning precision for keyway milling is determined by sight.
- Contact Miki Pulley when the keyway requires a positioning precision.
- Set screws are included with the product.
- Contact Miki Pulley regarding technical documentation for standard dimensions for bore processing other than those given here.

# SERVOFLEX SFH G-K-K - Datasheet

## DOUBLE ELEMENT / Conical clamp hub

### Specifications

Model	Rated torque [N·m]	Misalignment			Max. rotation speed [min <sup>-1</sup> ]	Torsional stiffness [N·m/rad]	Axial stiffness [N/mm]	Moment of inertia [kg·m <sup>2</sup> ]	Mass [kg]
		Parallel [mm]	Angular [°]	Axial [mm]					
SFH-150G-□K-□K	1000	1.4	2	± 0.8	5900	750000	122	31.41 × 10 <sup>-3</sup>	12.96
SFH-170G-□K-□K	1300	1.6	2	± 1.0	5100	1420000	112	72.09 × 10 <sup>-3</sup>	18.95
SFH-190G-□K-□K	2000	2.0	2	± 1.0	4700	1700000	122	98.15 × 10 <sup>-3</sup>	23.14
SFH-210G-□K-□K	4000	2.1	2	± 1.1	4300	2340000	254	137.53 × 10 <sup>-3</sup>	26.61

• Higher rpm possible with balancing.  
 • The moment of inertia and mass are specified for the maximum bore diameter.

### Dimensions

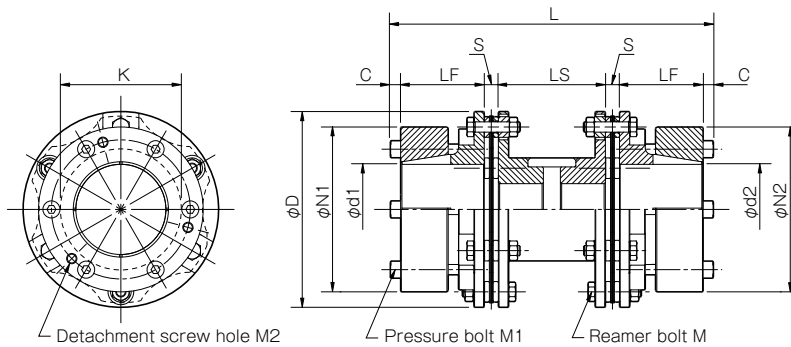

Model	D	L	d1 · d2	N1 · N2	LF	LS	S	C	K	M	M1	M2	Unit [mm]
SFH-150G-□K-□K	152	238	38 · 40 · 42 · 45 · 48 · 50	108	65	70	11	8	94	12-M8 × 36	6-M8 × 60	3-M8	
			55 · 56 · 60 · 65 · 70	128									
SFH-170G-□K-□K	178	254	38 · 40 · 42 · 45 · 48 · 50	108	65	80	14	8	108	12-M10 × 45	6-M8 × 60	3-M8	
			55 · 56 · 60 · 65 · 70	128									
			75 · 80	148									
SFH-190G-□K-□K	190	290	38 · 40 · 42 · 45 · 48 · 50	108	70	100	15	10	116	12-M12 × 54	6-M10 × 65	3-M10	
			55 · 56 · 60 · 65 · 70	128									
			75 · 80 · 85	148									
SFH-210G-□K-□K	210	306	38 · 40 · 42 · 45 · 48 · 50	108	73	110	15	10	124	12-M16 × 60	6-M10 × 65	3-M10	
			55 · 56 · 60 · 65 · 70	128									
			75 · 80 · 85 · 90	148									

• Further dimensions for LS possible on request.

### Standard Bore Dimensions

Model	Standard bore diameter d1, d2 [mm]														
	38	40	42	45	48	50	55	56	60	65	70	78	80	85	90
SFH-150G-□K-□K	●	●	●	●	●	●	●	●	●	●	●	●	●	●	●
SFH-170G-□K-□K	1100	1200	1250	●	●	●	●	●	●	●	●	●	●	●	●
SFH-190G-□K-□K	1800	1900	●	●	●	●	●	●	●	●	●	●	●	●	●
SFH-210G-□K-□K	1800	1900	2000	2150	2300	2400	2600	2650	2850	3100	3350	3600	3800	●	●

• The bore diameters marked with ● or numbers indicate a standard bore diameter and the respective torque.  
 • Bore diameters whose fields contain numbers are restricted in their rated torque by the holding power of the shaft connection component because the bore diameter is small. The numbers indicate the rated torque value [N·m].

### How to Place an Order

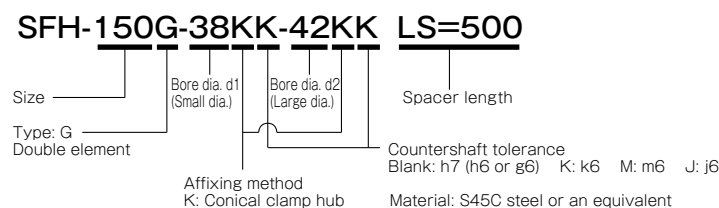

### Maximum LS Dimension When Used Vertically

Model	LS [mm]
SFH-150G-□K-□K	1100
SFH-170G-□K-□K	800
SFH-190G-□K-□K	900
SFH-210G-□K-□K	2000

• When considering vertical use and the LS dimension is greater than that in the above table, consult Miki Pulley.