

SERVOFLEX SFH S - Datasheet

SINGLE ELEMENT / Key/Set Screw Type

Specifications

Model	Rated torque [N·m]	Misalignment		Max. rotation speed [min ⁻¹]	Torsional stiffness [N·m/rad]	Axial stiffness [N/mm]	Moment of inertia [kg·m ²]	Mass [kg]
		Angular [°]	Axial [mm]					
SFH-150S	1000	1	± 0.4	5900	1500000	244	12.60 × 10 ⁻³	4.71
SFH-170S	1300	1	± 0.5	5100	2840000	224	26.88 × 10 ⁻³	7.52
SFH-190S	2000	1	± 0.5	4700	3400000	244	43.82 × 10 ⁻³	10.57
SFH-210S	4000	1	± 0.55	4300	4680000	508	68.48 × 10 ⁻³	13.78
SFH-220S	5000	1	± 0.6	4000	5940000	448	102.53 × 10 ⁻³	18.25
SFH-260S	8000	1	± 0.7	3400	10780000	612	233.86 × 10 ⁻³	29.66

• Max. rotation speed does not take into account dynamic balance.
 • The moment of inertia and mass are specified for the maximum bore diameter.

Dimensions

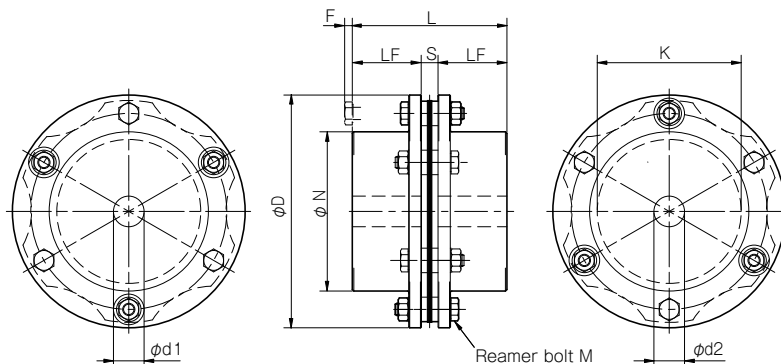

Model	d1 · d2			D	N	L	LF	S	F	K	M
	Pilot bore	Min.	Max.								
SFH-150S	20	22	70	152	104	101	45	11	5	94	6-M8 × 36
SFH-170S	25	28	80	178	118	124	55	14	6	108	6-M10 × 45
SFH-190S	30	32	85	190	126	145	65	15	10	116	6-M12 × 54
SFH-210S	35	38	90	210	130	165	75	15	8	124	6-M16 × 60
SFH-220S	45	48	100	225	144	200	90	20	-2	132	6-M16 × 60
SFH-260S	50	55	115	262	166	223	100	23	11	150	6-M20 × 80

Unit (mm)

How to Place an Order

SFH-150S-38H-38H

Size: 150S, Type: S, Bore diameter: d1 (Small diameter) - d2 (Large diameter)
 Blank: Pilot bore, Single element

Bore specifications
 Blank: Compliant with the old JIS standards (class 2) E9
 H: Compliant with JIS standards H9
 N: Compliant with motor standards

Material: S45C steel or an equivalent

Standard Hole-Drillings

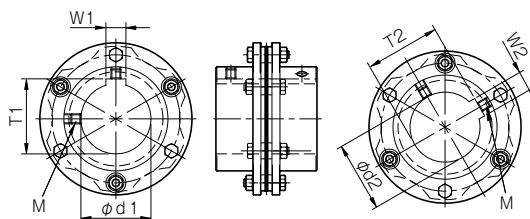

Unit [mm]

Models compliant with the old JIS standard (class 2) JIS B 1301 1959					Models compliant with the new JIS standard (H9) JIS B 1301 1996					Models compliant with the motor standard JIS C 4210 2001				
Nominal bore diameter	Bore diameter [d1 · d2]	Keyway width [W1 · W2]	Keyway height [T1 · T2]	Set screw hole [M]	Nominal bore diameter	Bore diameter [d1 · d2]	Keyway width [W1 · W2]	Keyway height [T1 · T2]	Set screw hole [M]	Nominal bore diameter	Bore diameter [d1 · d2]	Keyway width [W1 · W2]	Keyway height [T1 · T2]	Set screw hole [M]
	Tolerance H7	Tolerance E9	—	—		Tolerance H7	Tolerance H9	—	—		Tolerance G7, F7	Tolerance H9	—	—
22	22 ^{+0.021} ₀	7 ^{+0.061} _{+0.025}	25.0 ^{+0.3} ₀	2-M6	22H	22 ^{+0.021} ₀	6 ^{+0.030} ₀	24.8 ^{+0.3} ₀	2-M5	—	—	—	—	—
24	24 ^{+0.021} ₀	7 ^{+0.061} _{+0.025}	27.0 ^{+0.3} ₀	2-M6	24H	24 ^{+0.021} ₀	8 ^{+0.036} ₀	27.3 ^{+0.3} ₀	2-M6	24N	24 ^{+0.028} _{+0.007}	8 ^{+0.036} ₀	27.3 ^{+0.3} ₀	2-M6
25	25 ^{+0.021} ₀	7 ^{+0.061} _{+0.025}	28.0 ^{+0.3} ₀	2-M6	25H	25 ^{+0.021} ₀	8 ^{+0.036} ₀	28.3 ^{+0.3} ₀	2-M6	—	—	—	—	—
28	28 ^{+0.021} ₀	7 ^{+0.061} _{+0.025}	31.0 ^{+0.3} ₀	2-M6	28H	28 ^{+0.021} ₀	8 ^{+0.036} ₀	31.3 ^{+0.3} ₀	2-M6	28N	28 ^{+0.028} _{+0.007}	8 ^{+0.036} ₀	31.3 ^{+0.3} ₀	2-M6
30	30 ^{+0.021} ₀	7 ^{+0.061} _{+0.025}	33.0 ^{+0.3} ₀	2-M6	30H	30 ^{+0.021} ₀	8 ^{+0.036} ₀	33.3 ^{+0.3} ₀	2-M6	—	—	—	—	—
32	32 ^{+0.025} ₀	10 ^{+0.061} _{+0.025}	35.5 ^{+0.3} ₀	2-M8	32H	32 ^{+0.025} ₀	10 ^{+0.036} ₀	35.3 ^{+0.3} ₀	2-M8	—	—	—	—	—
35	35 ^{+0.025} ₀	10 ^{+0.061} _{+0.025}	38.5 ^{+0.3} ₀	2-M8	35H	35 ^{+0.025} ₀	10 ^{+0.036} ₀	38.3 ^{+0.3} ₀	2-M8	—	—	—	—	—
38	38 ^{+0.025} ₀	10 ^{+0.061} _{+0.025}	41.5 ^{+0.3} ₀	2-M8	38H	38 ^{+0.025} ₀	10 ^{+0.036} ₀	41.3 ^{+0.3} ₀	2-M8	38N	38 ^{+0.050} _{+0.025}	10 ^{+0.036} ₀	41.3 ^{+0.3} ₀	2-M8
40	40 ^{+0.025} ₀	10 ^{+0.061} _{+0.025}	43.5 ^{+0.3} ₀	2-M8	40H	40 ^{+0.025} ₀	12 ^{+0.043} ₀	43.3 ^{+0.3} ₀	2-M8	—	—	—	—	—
42	42 ^{+0.025} ₀	12 ^{+0.075} _{+0.032}	45.5 ^{+0.3} ₀	2-M8	42H	42 ^{+0.025} ₀	12 ^{+0.043} ₀	45.3 ^{+0.3} ₀	2-M8	42N	42 ^{+0.050} _{+0.025}	12 ^{+0.043} ₀	45.3 ^{+0.3} ₀	2-M8
45	45 ^{+0.025} ₀	12 ^{+0.075} _{+0.032}	48.5 ^{+0.3} ₀	2-M8	45H	45 ^{+0.025} ₀	14 ^{+0.043} ₀	48.8 ^{+0.3} ₀	2-M10	—	—	—	—	—
48	48 ^{+0.025} ₀	12 ^{+0.075} _{+0.032}	51.5 ^{+0.3} ₀	2-M8	48H	48 ^{+0.025} ₀	14 ^{+0.043} ₀	51.8 ^{+0.3} ₀	2-M10	48N	48 ^{+0.050} _{+0.025}	14 ^{+0.043} ₀	51.8 ^{+0.3} ₀	2-M10
50	50 ^{+0.025} ₀	12 ^{+0.075} _{+0.032}	53.5 ^{+0.3} ₀	2-M8	50H	50 ^{+0.025} ₀	14 ^{+0.043} ₀	53.8 ^{+0.3} ₀	2-M10	—	—	—	—	—
55	55 ^{+0.030} ₀	15 ^{+0.075} _{+0.032}	60.0 ^{+0.3} ₀	2-M10	55H	55 ^{+0.030} ₀	16 ^{+0.043} ₀	59.3 ^{+0.3} ₀	2-M10	55N	55 ^{+0.060} _{+0.030}	16 ^{+0.043} ₀	59.3 ^{+0.3} ₀	2-M10
56	56 ^{+0.030} ₀	15 ^{+0.075} _{+0.032}	61.0 ^{+0.3} ₀	2-M10	56H	56 ^{+0.030} ₀	16 ^{+0.043} ₀	60.3 ^{+0.3} ₀	2-M10	—	—	—	—	—
60	60 ^{+0.030} ₀	15 ^{+0.075} _{+0.032}	65.0 ^{+0.3} ₀	2-M10	60H	60 ^{+0.030} ₀	18 ^{+0.043} ₀	64.4 ^{+0.3} ₀	2-M10	60N	60 ^{+0.060} _{+0.030}	18 ^{+0.043} ₀	64.4 ^{+0.3} ₀	2-M10
65	65 ^{+0.030} ₀	18 ^{+0.075} _{+0.032}	71.0 ^{+0.3} ₀	2-M10	65H	65 ^{+0.030} ₀	18 ^{+0.043} ₀	69.4 ^{+0.3} ₀	2-M10	65N	65 ^{+0.060} _{+0.030}	18 ^{+0.043} ₀	69.4 ^{+0.3} ₀	2-M10
70	70 ^{+0.030} ₀	18 ^{+0.075} _{+0.032}	76.0 ^{+0.3} ₀	2-M10	70H	70 ^{+0.030} ₀	20 ^{+0.052} ₀	74.9 ^{+0.5} ₀	2-M10	—	—	—	—	—
75	75 ^{+0.030} ₀	20 ^{+0.095} _{+0.040}	81.0 ^{+0.5} ₀	2-M10	75H	75 ^{+0.030} ₀	20 ^{+0.052} ₀	79.9 ^{+0.5} ₀	2-M10	75N	75 ^{+0.060} _{+0.030}	20 ^{+0.052} ₀	79.9 ^{+0.5} ₀	2-M10
80	80 ^{+0.030} ₀	20 ^{+0.095} _{+0.040}	86.0 ^{+0.5} ₀	2-M10	80H	80 ^{+0.030} ₀	22 ^{+0.052} ₀	85.4 ^{+0.5} ₀	2-M12	—	—	—	—	—
85	85 ^{+0.035} ₀	24 ^{+0.095} _{+0.040}	93.0 ^{+0.5} ₀	2-M12	85H	85 ^{+0.035} ₀	22 ^{+0.052} ₀	90.4 ^{+0.5} ₀	2-M12	85N	85 ^{+0.071} _{+0.036}	22 ^{+0.052} ₀	90.4 ^{+0.5} ₀	2-M12
90	90 ^{+0.035} ₀	24 ^{+0.095} _{+0.040}	98.0 ^{+0.5} ₀	2-M12	90H	90 ^{+0.035} ₀	25 ^{+0.052} ₀	95.4 ^{+0.5} ₀	2-M12	—	—	—	—	—
95	95 ^{+0.035} ₀	24 ^{+0.095} _{+0.040}	103.0 ^{+0.5} ₀	2-M12	95H	95 ^{+0.035} ₀	25 ^{+0.052} ₀	100.4 ^{+0.5} ₀	2-M12	95N	95 ^{+0.071} _{+0.036}	25 ^{+0.052} ₀	100.4 ^{+0.5} ₀	2-M12
100	100 ^{+0.035} ₀	28 ^{+0.095} _{+0.040}	109.0 ^{+0.5} ₀	2-M12	100H	100 ^{+0.035} ₀	28 ^{+0.052} ₀	106.4 ^{+0.5} ₀	2-M12	—	—	—	—	—
115	115 ^{+0.035} ₀	32 ^{+0.112} _{+0.050}	125.0 ^{+0.5} ₀	2-M12	115H	115 ^{+0.035} ₀	32 ^{+0.062} ₀	122.4 ^{+0.5} ₀	2-M12	—	—	—	—	—

Position of Set Screw

Model	Position of set screw [mm]
SFH-150	15
SFH-170	20
SFH-190	25
SFH-210	30
SFH-220	35
SFH-260	40

NOTE

- Positioning precision for keyway milling is determined by sight.
- Contact Miki Pulley when the keyway requires a positioning precision.
- Set screws are included with the product.
- Contact Miki Pulley regarding technical documentation for standard dimensions for bore processing other than those given here.

SERVOFLEX SFH S-K-K - Datasheet

SINGLE ELEMENT / Conical clamp hub

Specifications

Model	Rated torque [N·m]	Misalignment		Max. rotation speed [min ⁻¹]	Torsional stiffness [N·m/rad]	Axial stiffness [N/mm]	Moment of inertia [kg·m ²]	Mass [kg]
		Angular [°]	Axial [mm]					
SFH-150S-□K-□K	1000	1	± 0.4	5900	1500000	244	25.14 × 10 ⁻³	8.95
SFH-170S-□K-□K	1300	1	± 0.5	5100	2840000	224	47.90 × 10 ⁻³	12.53
SFH-190S-□K-□K	2000	1	± 0.5	4700	3400000	244	60.40 × 10 ⁻³	14.21
SFH-210S-□K-□K	4000	1	± 0.55	4300	4680000	508	80.50 × 10 ⁻³	16.12

• Higher rpm possible with balancing.
 • The moment of inertia and mass are specified for the maximum bore diameter.

Dimensions

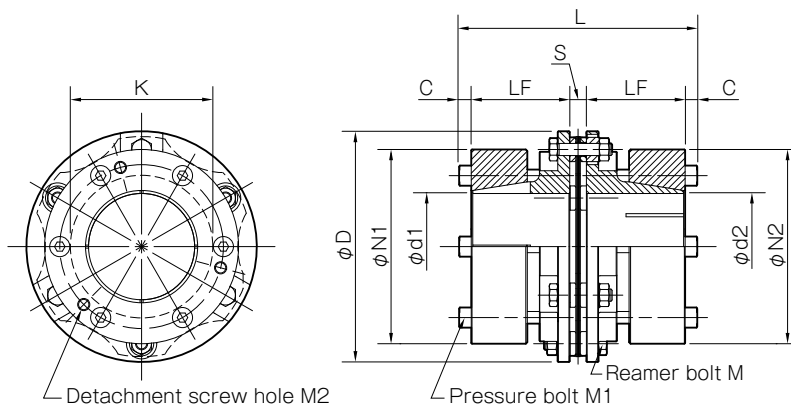

Model	D	L	d1 / d2	N1, N2	LF	S	C	K	M	M1	Unit [mm]	
											M2	M2
SFH-150S-□K-□K	152	157	38 · 40 · 42 · 45 · 48 · 50	108	65	11	8	94	6-M8 × 36	6-M8 × 60	3-M8	M2
			55 · 56 · 60 · 65 · 70	128								
SFH-170S-□K-□K	178	160	38 · 40 · 42 · 45 · 48 · 50	108	65	14	8	108	6-M10 × 45	6-M8 × 60	3-M8	M2
			55 · 56 · 60 · 65 · 70	128								
			75 · 80	148								
SFH-190S-□K-□K	190	175	38 · 40 · 42 · 45 · 48 · 50	108	70	15	10	116	6-M12 × 54	6-M10 × 65	3-M10	M2
			55 · 56 · 60 · 65 · 70	128								
			75 · 80 · 85	148								
SFH-210S-□K-□K	210	181	38 · 40 · 42 · 45 · 48 · 50	108	73	15	10	124	6-M16 × 60	6-M10 × 65	3-M10	M2
			55 · 56 · 60 · 65 · 70	128								
			75 · 80 · 85 · 90	148								

Standard Bore Dimensions

Model	Standard bore diameter d1, d2 [mm]														
	38	40	42	45	48	50	55	56	60	65	70	78	80	85	90
SFH-150S-□K-□K	●	●	●	●	●	●	●	●	●	●	●				
SFH-170S-□K-□K	1100	1200	1250	●	●	●	●	●	●	●	●	●	●		
SFH-190S-□K-□K	1800	1900	●	●	●	●	●	●	●	●	●	●	●	●	
SFH-210S-□K-□K	1800	1900	2000	2150	2300	2400	2600	2650	2850	3100	3350	3600	3800	●	●

• The bore diameters marked with ● or numbers indicate a standard bore diameter and the respective torque.
 • Bore diameters whose fields contain numbers are restricted in their rated torque by the holding power of the shaft connection component because the bore diameter is small. The numbers indicate the rated torque value [N·m].

How to Place an Order

SFH-150S-38KK-42KK

Size: 150 (SFH-150S)
 Type: S (Single element)
 Bore dia. d1 (Small dia.): 38 (KK)
 Bore dia. d2 (Large dia.): 42 (KK)
 Affixing method: K (Conical clamp hub)
 Countershaft tolerance: Blank (h7 (h6 or g6) K: k6 M: m6 J: j6)

Material: S45C steel or an equivalent